



518 Pratt Ave. ~ Schaumburg, Il. 60193

8 0 0 - 3 3 6 - 4 8 6 4

8 4 7 - 3 5 2 - 1 1 0 1 (fax)

**INSTALLATION INSTRUCTIONS
COMMON AUDIBLE CONTROL UNIT**

MODEL: CA-312-1

Use this product according to this instruction manual. Please keep this instruction manual for future reference.

APPLICATION INFORMATION:

IF ANY WORDS OR LETTERS APPEAR ON THE PRODUCT INDICATING A PARTICULAR USE, THE PRODUCT MUST BE USED ONLY IN THE MANNER SO INDICATED. THE INSTALLATION OF THIS EQUIPMENT SHOULD ONLY BE UNDERTAKEN BY QUALIFIED PERSONNEL. FIELD ADJUSTMENT, REPAIR OR MODIFICATION OF THESE SIGNALS SHOULD NOT BE ATTEMPTED. Malfunctioning units should be returned for factory repair or replacement in accordance with Wheelock Inc.'s published terms and conditions. Contact Wheelock Inc., 273 Branchport Ave., Long Branch, NJ, 07740.

NOTE: All **CAUTIONS** and **WARNINGS** are identified by the symbol . All warnings are printed in bold capital letters.

FCC REGULATIONS:

- This equipment complies with Part 68 of the FCC Rules. The label affixed to this product contains, among other information, the FCC Registration Number and the Ringer Equivalence Number (REN) for this product. This information must be provided to the telephone company if requested.
- The REN is used to determine the quantity of devices which you may connect to your telephone line and still have all of those devices ring when your telephone number is called. In most, but not all areas, the sum of the REN's of all devices connected to one line should not exceed five (5.0). To be certain of the number of devices that you may connect to your line, contact your local telephone company.
- This equipment should not be used on coin telephone lines. Connection to party line service is subject to state tariffs.
- If trouble is experienced, disconnect this equipment from the telephone line to determine if it is causing the malfunction. If the equipment is determined to be malfunctioning, its use shall be discontinued until the problem has been corrected.
- Should the equipment cause harm to the telephone network, the telephone company shall, if possible, notify the customer that temporary discontinuance of service may be required; however, where prior written notice is not possible, the telephone company may temporarily discontinue service without notice, if such action is necessary under the circumstances. The telephone company may make changes in its communication facilities, equipment and operations procedures, where such action is reasonably required in the operation of its business and is not inconsistent with the rules and regulations of the Federal Communications Commission.

DOC REGULATIONS:

NOTICE: The Canadian Department of Communications label identifies certified equipment. This certification means that the equipment meets certain telecommunications network protective operational and safety requirements. The Department does not guarantee the equipment will operate to the user's satisfaction.

- Before installing this equipment, users should ensure that it is permissible to be connected to the facilities of the local telecommunications company. The equipment must also be installed using an acceptable method of connection. In some cases, the company's inside wiring associated with a single line individual service may be extended by means of a certified connector assembly (telephone extension cord). The customer should be aware that compliance with the above conditions may not prevent degradation of service in some situations.
- Any repairs or alterations made by the user to this equipment, or equipment malfunctions, may give the telecommunications company cause to request the user to disconnect the equipment.
- Make sure that the electrical ground connections of the power utility, telephone lines and internal metallic water pipe system, if present, are connected together.

 **CAUTION:** The installation of this equipment should only be undertaken by qualified personnel.

- The Load Number (LN) assigned to each terminal device denotes the percentage of the total load to be connected to a telephone loop which is used by the device, to prevent overloading. The termination on a loop may consist of any combination of devices subject only to the requirement that the total of the Load Numbers of all the devices does not exceed 100.

Load Number for CA-312-1 = 17

Copyright 2001 Wheelock, Inc. All rights reserved.

GENERAL INFORMATION:

The CA-312-1 Common Audible Control Unit can monitor up to three telephone lines to provide "all call" signaling. To monitor additional input lines use a CA-622-1 (P81534). These interface products are especially useful for new electronic key systems that do not offer a common audible ring circuit for night bell connection or zoned ringing. A choice of two outputs for connection of alert signals is provided: standard ringing voltage output or dry contact closure. A wide selection of audible and visual alert signals is available to operate directly off the ringing voltage output. Alternatively, Wheelock's Dry Contact Interface (Model DCI-24-24) can be connected to the optional contact closure output to drive multiple 24VDC alert signals.

SPECIFICATIONS:

Signal Input Quantity	From 1 to 6 Incoming C.O. Lines
Signal Input Voltage	55-130VAC
Signal Input Frequency	20-30Hz
Signal Output	90/20 Incoming Signal
Contact Output	A Dry Contact rated at 2 Amps, @ 24VDC
Expansion	Units are gangable
Ringer Equivalence	1.0 A
Signaling Zones	1
Dimensions	7-1/4" X 5" X 2"

INSTALLATION INFORMATION:

The CA-312-1 Common Audible Control Unit is designed for mounting on or near the key telephone system. Locate the control as desired. Remove the top cover and mount the bottom using the mounting screws and holes provided. See Figure 1. Connect from 1 to 3 incoming C.O. Lines to the Input Terminals T1 through T3 and R1 through R3. Connect earth ground to Input Terminal. When using 90V/20Hz output place "Zone A" switch in "90/20Hz" position; connect 90/20Hz signal to "90/20" output on output terminals 2 and 3. When using a dry contact output place "Zone A" switch in "Dry Contact symbol" position; Connect Wheelock's DCI-24-24 or EPS-2401 Power Supplies with Wheelock's 24VDC Alert Signals.

Before closing the box of the control unit have someone call each of the connected C.O. lines to be sure they are triggering the appropriate signals.

CAUTION: For proper installation check ground connection and proper tip/ring orientation when hooking up the unit.

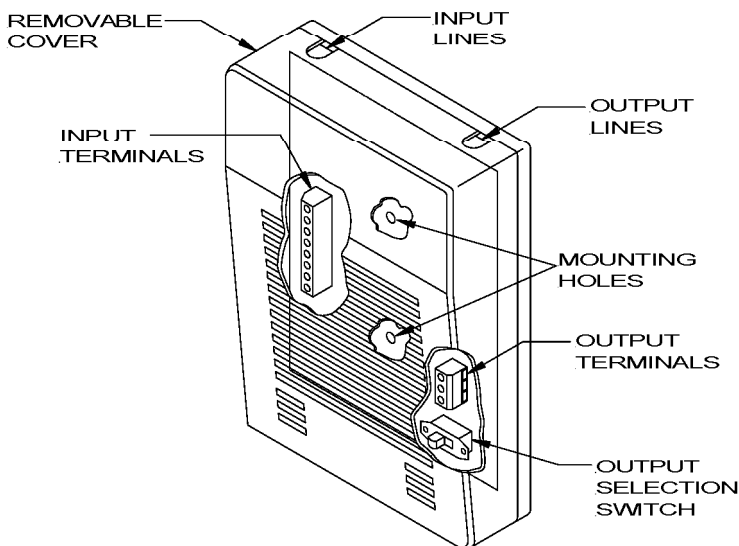

Figure 1.

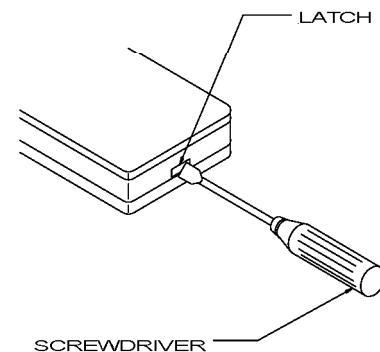

Figure 2.

CAUTION: For proper installation check ground connections and proper tip/ring orientation when hooking up the unit.

TELE-MOVERS, INC

518 Pratt Ave. ~ Schaumburg, Il. 60193

800-336-4864

847-352-1101 (fax)

INSTALLATION NOTES:

1. Connect earth ground to top input terminal as indicated when using the 90/20 ring signal on output terminals.
2. For Dry Contact output earth ground connection is not required.
3. Use separate earth ground line to avoid stray signal pick-up.
4. Do not use ringing voltage output when common audible control unit is connected in front of a PBX with ground start (rather than loop start) C.O. lines. Use dry contact output in these cases.
5. For proper installation, check ground connection and proper tip/ring orientation when hooking up the unit.

⚠ CAUTION: These devices are not intended for use in hazardous locations as defined by the National Electrical Code (NEC) and by the National Fire Protection Association (NFPA).

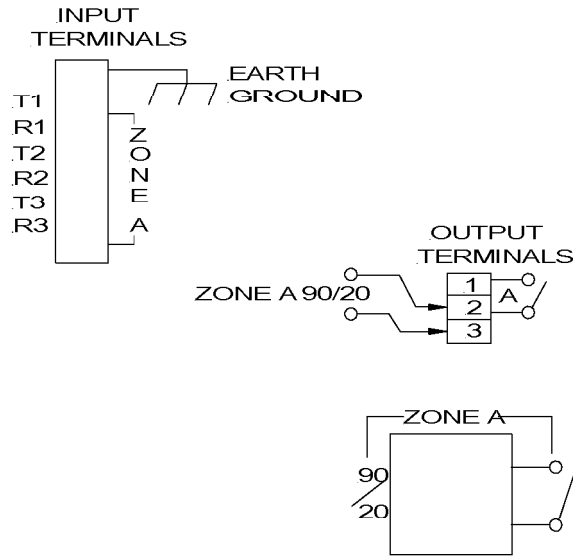

Figure 3.
See Note 5 Concerning Earth Ground

CONDITION

1. Relay trip is heard, but signal does not operate.

CHECK

- A. Is there a ring voltage between each "ring" terminal and the "earth ground" terminal on the input terminal block?
NO - Go to B.
YES - Check for ring voltage between terminals 2 and 3, or 3 and 4, on the output terminal block.
- B. Is there a ring voltage between each "Tip" terminal and the "earth ground" terminal, on the input terminal block?
NO - Go to C.
YES - Reverse the input wires since tip and ring are reversed.
- C. Earth ground is not adequate. Reconnect to a better ground and check ring voltage on output terminals.



518 Pratt Ave. ~ Schaumburg, Il. 60193

8 0 0 - 3 3 6 - 4 8 6 4

8 4 7 - 3 5 2 - 1 1 0 1 (fax)